

MCINTOSH

Forage Wagon

User Manual

McIntosh Brothers Engineers Ltd
Phone 06 356 7056 - Fax 06 356 7055
PO Box 4240
PALMERSTON NORTH 4442
NEW ZEALAND
www.mcintosh.net.nz



MCINTOSH
FARM MACHINERY

Forage Wagon

GENERAL OPERATION AND MAINTENANCE INSTRUCTIONS

MANUFACTURED BY
McINTOSH BROTHERS
ENGINEERS LTD
PALMERSTON NORTH
NEW ZEALAND

DISTRIBUTED BY

Safety must have **PRIORITY**

- **Maintain your machine in good working condition.**
- **Keep all guards and shields in place.**
- **Disconnect hydraulic supply lines when any maintenance, greasing or adjustments are undertaken.**
- **Keep hands, feet, clothing, away from power driven parts.**
- **Keep other people clear of machine when in use.**
- **Always shut down hydraulics when you leave the tractor seat.**
- **Do not allow people to travel on your forage wagon.**

**HUMAN ERROR IS THE MAJOR FACTOR IN
ACCIDENTS**

Check List PRIOR to Operation

- Never run forage wagon at over 36 kph as damage could occur.
- Remove wires holding the centre feed discharge flaps. These have been used for transportation purposes only.
- Adjust centre feed flaps to approximately 600mm. This measurement will vary depending on type of material being fed out.
- Look over all bolts to check none have come loose after transport from factory.
- Check all wheel nuts for tightness.
- Connect hydraulic hoses to tractor, run up machine, and check slow and fast feeds of floor chains.
- Please show all persons operating this machine the manual before operating for the first time.

The first time you use your wagon, if the floor does not move forward, screw the bronze pressure valve knob which is under the valve, in $\frac{1}{2}$ a turn at a turn until the floor starts to move forward.

**NOTE: ALL MACHINES ARE RUN UP PRIOR TO LEAVING THE FACTORY
BUT THE ABOVE STEPS SHOULD BE DONE PRIOR TO USE**

GENERAL OPERATING INSTRUCTIONS

- Never load higher than sides; load evenly.
- Tease materials out when loading.
- Load clear of elevator where possible.
- Run machine in neutral position to clear elevator prior to engaging floor chains. (**NOTE** *this mainly refers to heavy loading*).
- Make sure the cross conveyor (if fitted) is clearing materials properly.
- If a build up occurs, this can result in material being taken back around the elevator.
- When feeding two crops together, load the lighter material on bottom.
- Use slow speeds for wet or heavy materials.
- For even feeding load the machine evenly.
- Tractor ground speed is approximately 6-8 kilometres per hour, but this will vary to suit conditions and density of row you require.
- Never run full load on fast speed. Place speed control in slow position and operate in this manner. Use fast speed when clearing the last 20-25% of load.
- When cleaning the machine, turn the tractor hydraulics off as well as the tractor itself before leaving the tractor seat.
- When clearing any blockages or checking the machine for faults, turn the tractor hydraulics off as well as the tractor itself before leaving the tractor seat.

GREASING AND MAINTENANCE

Make sure your machine is well greased (refer to list for greasing points).

Wagon Grease Nipples

Swivel	1
Jack	1
Conveyor	4
Elevator (2 chain)	9
Elevator (4 chain)	15
Floor shaft (2 chain)	4
Floor shaft (3 chain)	4
Floor shaft (4 chain)	5
Single axle	2
Tandem axle	6
Floor idlers	1 per chain

Grease all nipples daily for the first week when in use, then weekly after that. If you are doing a lot of travelling, then the axle pins should be greased more often. Grease daily if the wagon is being used all day and doing a lot of kilometres. Check wheel bearings periodically.

Grease drive chains regularly, oil floor and elevator chains periodically which will give smoother running, particular when the machine has not been used for a while.

Check floor and elevator chains after the first three to four loads for tension and then once per week when in use. (*See illustration 1*) for adjusting.

If the floor or elevator chains get to the stage where it is possible to cut two links off each side then do so. If the chains are adjusted out further and further then at some point serious damage will be caused.

Floor slats bolts should be tightened up after the first week of operation and then monthly after that.

Check the cross conveyor belt regularly. If the tracking strip in the middle of the belt on a 900 wide conveyor or on the outsides on a 1200 conveyor is starting to climb the roller then the belt needs to be adjusted. The belt needs to be flat across the width of it otherwise damage will occur. If you are unsure about the tracking strip, please ring your supplier or us.

Check cross conveyor rollers for any build up of silage. If build up exists, remove the belt and clean thoroughly. Build up causes belt stretching and shortens belt life.

The cross conveyor belt should be removed once a year so that any build up of material can be cleaned out.

Grease is cheap - use it. Set a time each week to adjust and grease your wagon and you will save money and hassles in the future.

STORAGE

When machines are not in use, wash down thoroughly and apply a good coating of oil to the body, elevator and floor chains (half oil/half diesel does the job well).

BELT CONVEYOR

Slacken off cross conveyor belt adjusters which will eliminate the belt sticking to belt cover strips if the machine is not in use for a period of time.

ROLLER CHAIN CONVEYOR

Oil the roller chain when finished for the season, otherwise the links may seize up.

ELEVATOR & FLOOR CHAIN ADJUSTMENTS

ILLUSTRATION No. 1

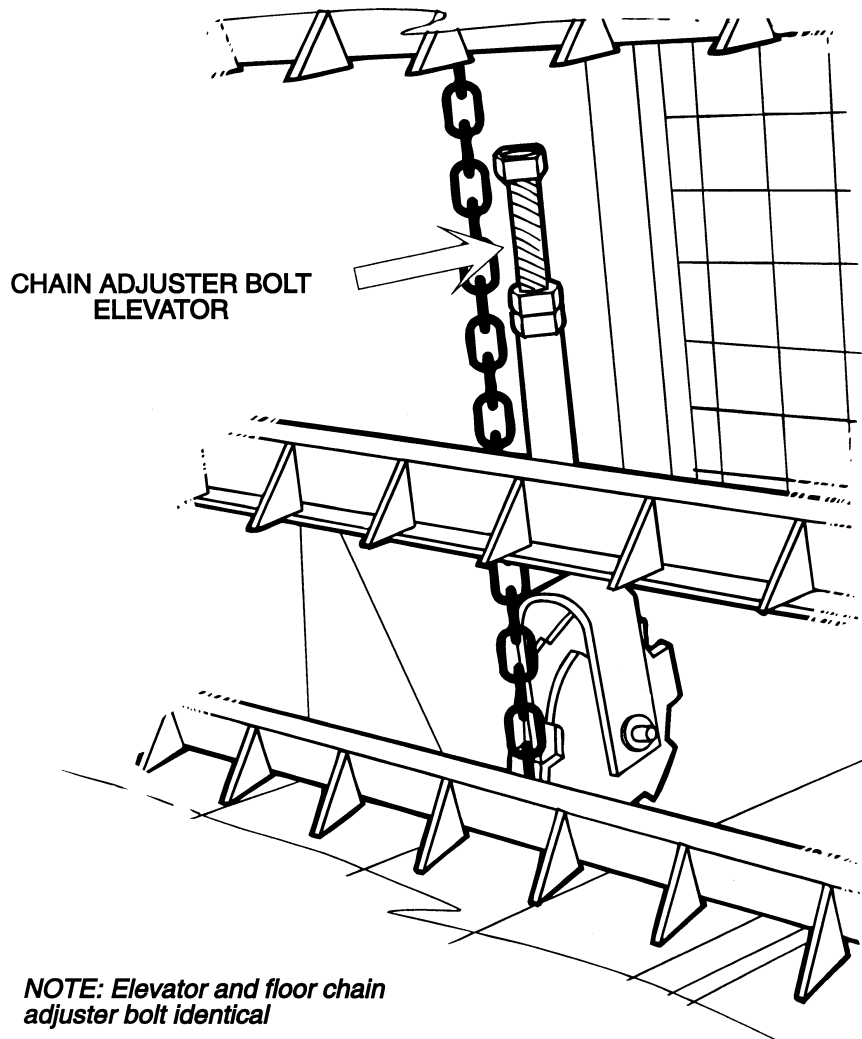

ELEVATOR CHAINS

To check adjustment, press chains vertically towards the elevator frame and there should be no more than 20-25mm deflection.

FLOOR CHAINS

To tension up floor chains, have one floor slat directly under the rear cross member. Adjust up floor chains until there is a 5mm gap between the floor slat and the angle iron of the bottom body at both ends of the slat.

SAFETY

Always disconnect the wagon from tractor hydraulics before making any adjustments or working on the machine.

CROSS CONVEYOR BELT ADJUSTMENT

McIntosh Brothers Forage wagons are fitted with a tracking strip on all cross conveyor belts. If your belt does require adjusting, it may be due to belt stretch or material build-up under the belt. Use the following procedure:

1. Check rollers and conveyor tray for any material build up. If some exists, slacken off the two rear adjusters and remove the belt joining pin. This will allow access for cleaning.
2. When clean, re-join the belt and adjust to the previous position.
3. Start the machine and run up to check for belt alignment and tension.
4. If the belt is off line, tighten the rear adjuster on the side the belt is running off on. Only move the adjuster $\frac{1}{4}$ to $\frac{1}{2}$ turn per time and allow machine to run three to four minutes for the belt to retrack, repeat procedure till correct position is achieved (***see illustration No. II***) for adjuster position.
5. Never over tension the belt as this can cause stretching and put more strain on the rollers. Make sure the adjuster lock nuts are firmly tightened after completion. For correct tension adjustment to take out belt slack, tighten further by 6mm. For further advice, regarding adjustments check with your Supplier or the Manufacturer.

CROSS CONVEYOR

ILLUSTRATIONS No. II

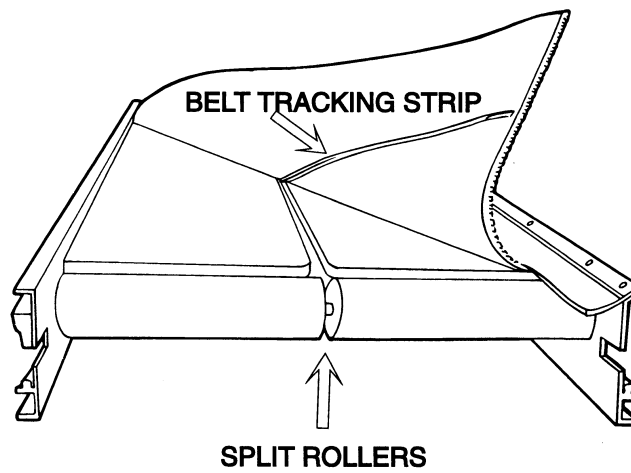
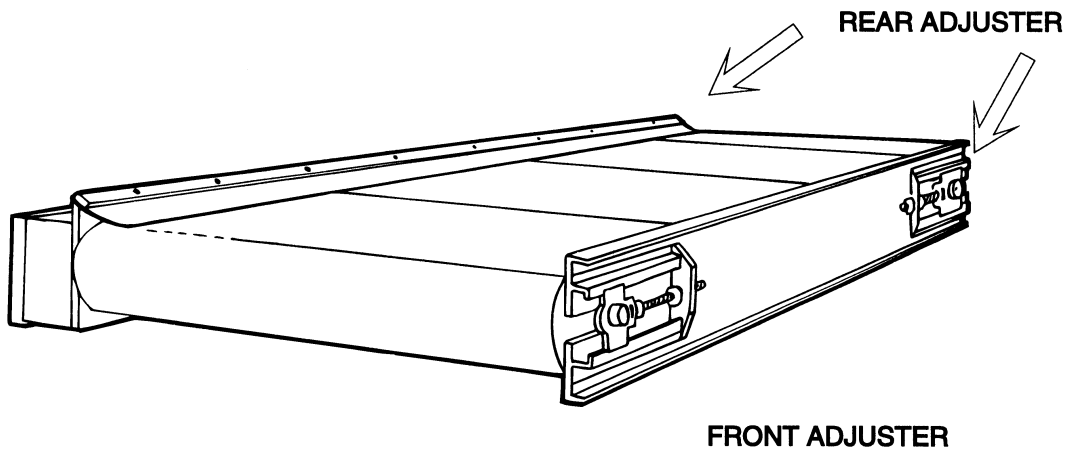
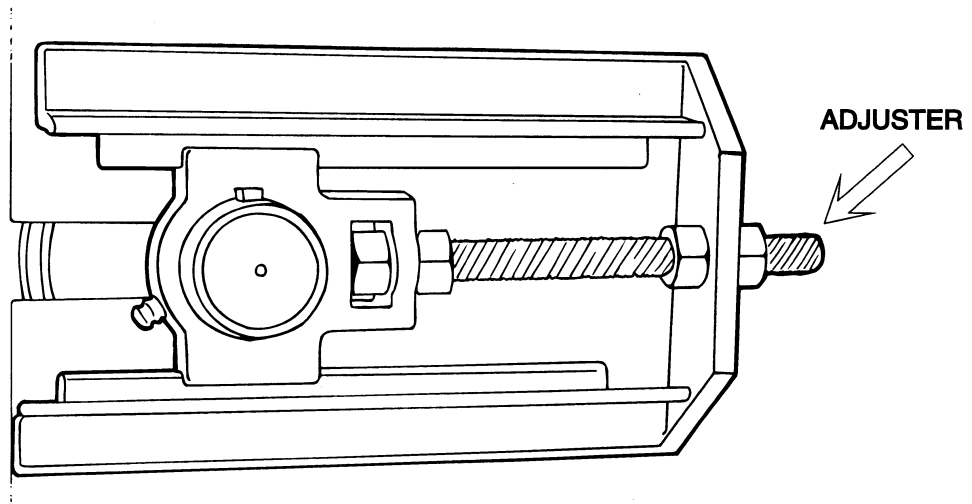

HYDRAULIC VALVE

There are two adjustable settings on the valve

- Floor speed control
- Floor pressure relief setting

Floor speed control

(See illustration No III)

The floor should not be moving when the indicator is against the slow stop. To adjust, undo the bolt on the clamp and turn the control lever till the floor stops moving.

Floor pressure setting

This is the adjustable cartridge on the bottom of the valve. This valve will divert the oil from going to the floor motor, it will instead go back to the tractor. The oil is diverted when the floor is getting overloaded and will go back to the floor motor once the elevator has cleared the load against it. To get more pressure to the floor, undo the locking nut on the valve, then screw the knob clockwise ½ a turn at a time, then run the wagon to check if this is the correct setting for your tractor and loading. To get less pressure to the floor, turn the knob anti clockwise.

You may need to screw the valve in:

- **The first time you use the wagon and the load does not come forward.**
- **If you travel further and get more compacting.**
- **If you load the wagon at night and it rains. This will make the load heavier.**
- **If you change pits and the second pit has heavier silage.**

If you screw the valve right in and leave it there, you will have very little protection on the floor. If you then have a jam there is a good chance, you will do damage to the machine.

The motors and valve on the wagon are sized and set to meet the size load the wagon can carry with the average tractor oil flow and pressure that could be pulling the wagon. With smaller wagons, you can get away with a tractor that may not be up to specifications with flows and pressure, but when you get up to the larger wagons, if the tractor has not got the performance or not working to its specifications, then the wagon may not feed out as expected.

HYDRAULIC CONTROL VALVE

ILLUSTRATION No. III

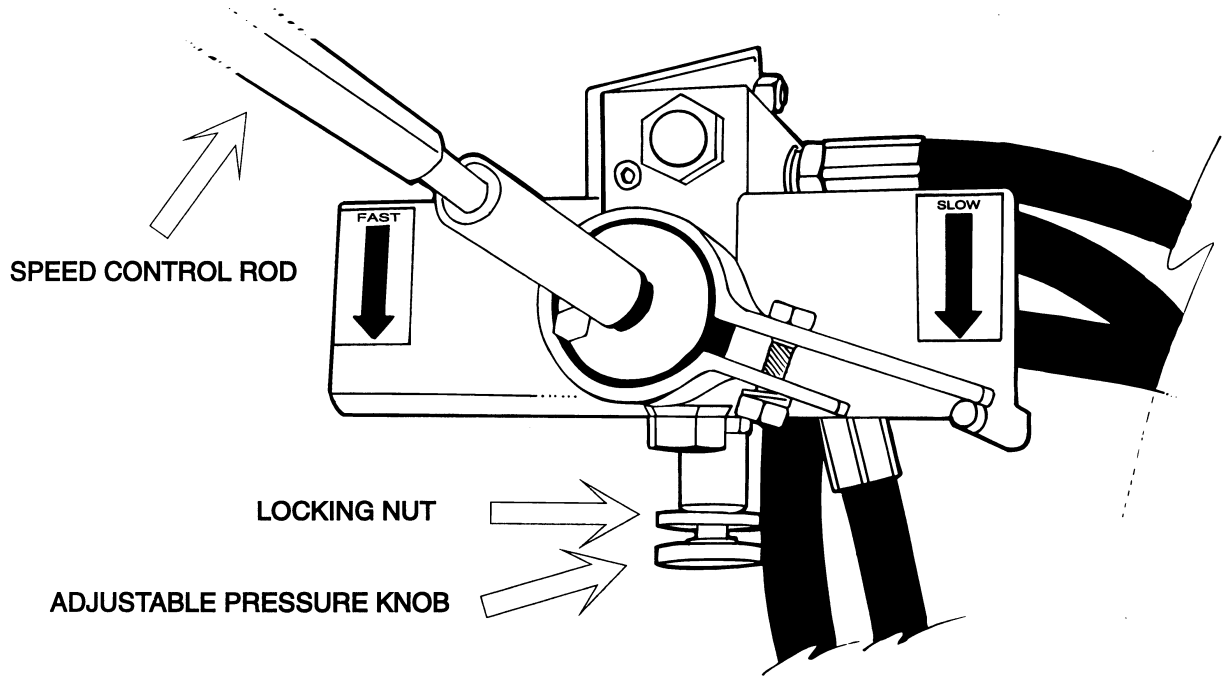

REAR DOOR ADJUSTERS

(See illustration no IV)

Spring loaded catches are fitted as a precaution against faulty machine use, such as engaging reverse when fully loaded by mistake.

When rear unloading, a manual trip rope is more practical than relying on the spring loaded catches due to variable ground contour.

Grease can be used on pin and catch, but remember this will probably allow the door to open more easily.

REAR DOOR LOCKING LATCHES

ILLUSTRATION No. IV

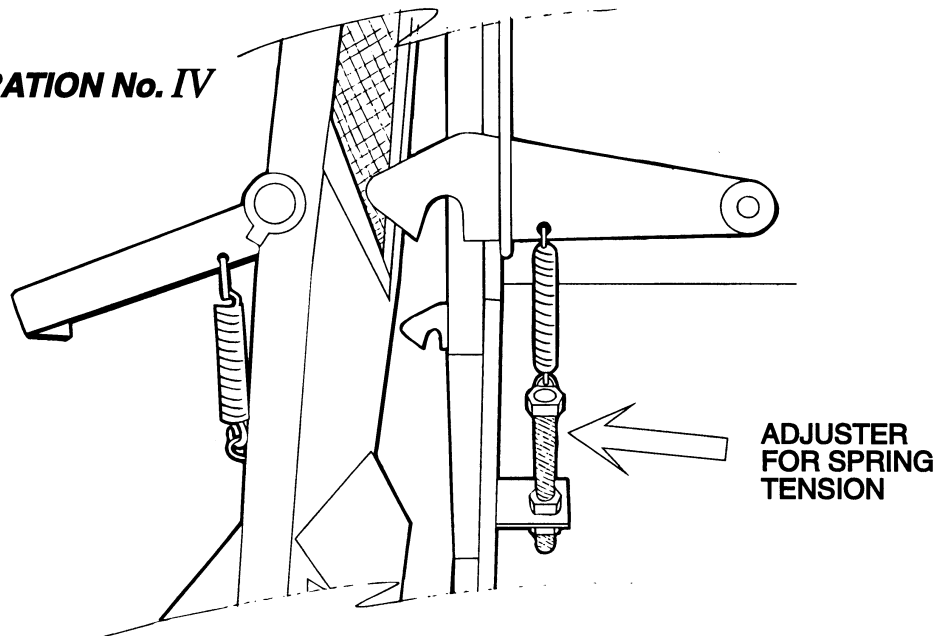

Reasons for the wagon not performing correctly

The valve pressure setting is wrong.

A problem with the tractor

- the tractor is too small oil wise for the wagon or loading
- the pump is not working to its full capacity
- tractor relief valves are not working properly
- quick release fitting is not letting enough oil through

A valve in the hydraulic block not working correctly due to something in the oil jamming the valve either opened or closed.

Cross conveyor

- Belt too loose
- Belt not adjusted correctly
- Keys loose in coupling between hydraulic motor and roller
- Bearing problems

Reasons to alter the pressure settings

Turn the valve in to increase the pressure to the floor because the floor will not move.

- First time using the wagon and the floor will move forward
- Load compacts while travelling
- Load left overnight and has compacted
- Feeding out a very heavy material

Turn the valve out to decrease the pressure to the floor when there is too much material coming over the top of the elevator.

COMMON FAULT PROBLEMS

- If the floor or elevator chains get to the stage where it is possible to cut two links off each side then do so. If the chains are adjusted out further and further then at some point serious damage will be caused.
- If the valve is screwed right in and left there, there will be very little protection on the floor.
- Please show all persons operating this machine the manual before operating for the first time.
- These wagons are designed to operate at 30-40 litres per minute. If the machine is run at 60-80 litres per minute, the wear and tear is accelerated on the chains and belt by approximately five times.
- Most problems occur by lack of maintenance and adjustments. Save yourself money and hassles.
- Machines need to be greased/adjusted regularly. There is no excuse for not making time to do this. If you do not grease or adjust the chains, you will have problems with the machine. When problems do occur, chances are that they will be at the worst time.

TYRE PRESSURES

Tyre Size	PSI
11.5/80-15.3	69
12.5/80-15.3	68
400/60-15.5	50
15/70 x 18	62
500/60-22.5	44
550/60-22.5	40
600 x 40 x 22.5	41
600/50-22.5	39
385/65 R22.5	68